

ET Ethernet Module Reference Manual

Revision: Aug 25, 2004

2344 Walsh Ave., Bldg F
Santa Clara, CA 95051
(408) 982-0660 Voice

Overview

The ET Ethernet Module adds a 10Mbit Ethernet port to ET system boards. The port can be used to program system boards, or to transfer data between a PC and a system board.

The Ethernet module is built around the Uvicom IP2022 chip that provides both a media access controller (MAC) and physical interface (PHY). The Uvicom chip drives the four JTAG programming signals, and it also communicates with the system board via a 14-signal interface modeled after the “Enhanced Parallel Port” (EPP) protocol. Firmware in the Uvicom chip works with ET’s PC-based Adept software to coordinate JTAG programming and user data transfers.

For JTAG programming, the ET Adept software tools can transfer .bit or .svf files directly to the Uvicom chip, where the resident firmware then drives the JTAG chain as required. See the *ET Adept Reference Manual* for more information. Both the Adept software and reference manual are available for download from the ET website.

For user data transfers, ET provides a DLL, API, the required Windows drivers, and a VHDL reference design (for inclusion in the system board). The DLL, API, and drivers can be downloaded and installed as a part of the ET Adept software available at the ET website. The VHDL reference design is available as a separate download. See the *ET Port Communications Reference Manual*, the *ET Parallel Interface Model Reference Manual*, and the VHDL source file “dpimref.vhd” for more information).

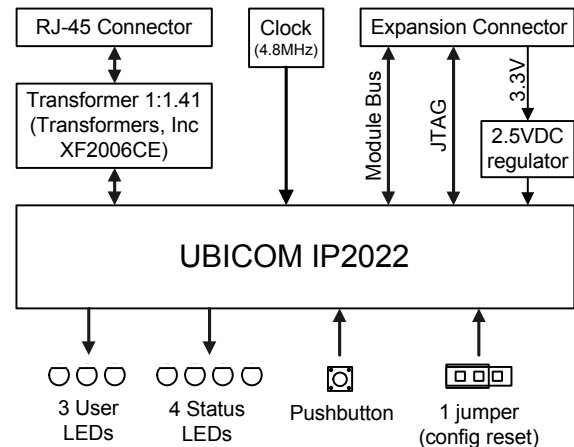

Figure 1. Ethernet Module Block Diagram

The ET Ethernet Module is compatible with all newer ET system boards (including the S-3 Starter, Pegasus, D2SB, and D2FT boards). It can also be used with the older D2 and D2E for user data transfers (but not for programming – see the individual board documentation for more information). The module should generally be connected to the A1, B1, or C1 expansion connector for proper operation. The module can be connected at other expansion connectors, but JTAG programming will not be available.

In operation, it is recommended that the system board be turned off prior to connecting the Ethernet module.

UbiCom IP2022

The Uvicom IP2022 provides an “all in one” 10Mbit Ethernet connectivity solution that includes a MAC, PHY, and processor. ET has written firmware for the processor that allows the Uvicom part to easily support JTAG

programming and user data transfers. ET also supplies Windows DLLs, APIs, and drivers that can be used in custom Windows applications to transfer data between a system board and an attached PC.

The firmware in the Ubicom chip can be modified using the Ubicom UNIVDNET kit available from Ubicom. ET does not offer any independent method or user support for modifying the firmware.

Module Initialization

Before the Ethernet Module can be used, it must be associated with a unique ID tag so that the ET Adept software can locate it. The Adept software can locate a module using any one of three ID tags: an alphanumeric name; a MAC address; or an IP address. Before the module can be connected to a general network, it must also be assigned a unique IP address. ET provides an "Ethernet Administrator" tool as a part of the Adept software that can be used to assign ID tags, including an IP address (see the *ET Adept Reference Manual* for more information).

The Ubicom chip is configured with a unique MAC address during manufacturing. The MAC address is printed on a sticker affixed to the board. By default, DHCP service is enabled on the module, so that IP addresses and a subnet mask can be automatically assigned from a DHCP server when the board is first attached to a network. If a DHCP server is not available, then the subnet mask and IP address stored in the Ubicom part will be used. The default subnet and IP settings are shown below. Note these settings may not be suitable for a given installation, and they may need to be changed (using the Ethernet Administrator) before the module can be used.

Default settings on the module are:

- Module ID (DModNet1)
- IP address (192.168.0.2)
- Subnet mask (255.255.255.0)
- Default Gateway (0.0.0.0)
- DHCP setting (enabled)

These default settings can be automatically restored at any time by loading a shorting block on the Configuration Reset Jumper (JP1) and power-cycling the board.

If the Ethernet Module fails to respond, the IP address and subnet mask may not be compatible with the current subnet. In this event, the Configuration Reset jumper should be shorted to restore factory defaults.

Connecting to Module

After the Ethernet module has been initialized, it is ready to be used by applications. To use the module either for JTAG programming or user data transfers, it must first be identified within the Adept software. Modules are identified by adding one or more of their ID tags to a "Device Table" list. This list is accessed through the "Communications Module" dialog box in Adept Suite (see the *ET Adept Reference Manual* for more information). Once the module has been identified, JTAG programming and user data transfers can commence.

Application Software

ET provides a Software Development Kit that contains the DLLs, APIs, and necessary Windows drivers to allow users to create their own application software to transfer data to a system board over the Ethernet. ET also provides two application programs that can be used to transfer data. These applications, called Export (used for JTAG programming) and Transport (for user data transfers) are available as a part of the Adept software. See the *ET Software Development Kit Reference Manual* and *ET Adept Reference Manual* for more information on these applications.

User I/O

The Ethernet Module contains several I/O devices, including an “ID” pushbutton, a configuration reset jumper, and three status LEDs.

ID button

When this button is pressed, the Ethernet Module sends a UDP broadcast containing all of the current settings. This broadcast is captured and displayed in the Communications Modules dialog box (see ET Adept Suite User’s Manual).

Configuration Jumper

The configuration jumper at JP1 will be sampled by the firmware when the board is powered on, and periodically thereafter. When loaded, the firmware will reset all factory defaults listed above. The jumper must be removed before the module can be used.

Status LEDs

Lnk: High when a solid Ethernet connection is made.

Act: High when the board is actively responding to a command.

Col: High when a packet collision is detected.

Other Useful Information

The following items are all available for free download from the ET website.

Documents

- ET Adept Reference Manual
- ET Port Communications Reference Manual
- ET Parallel Interface Model Reference Manual
- ET JTAG Scan Reference Manual

Software

- ET Adept Suite
- ET Adept Software Developers Kit

Reference Designs

- VHDL source file “dpimref.vhd”

Pinout table

The table below provides the pin assignments for the expansion connector.

Pin #	Signal
1	TDI
2	TDO
3	TMS
4	TCK
5	INT
6	JTSEL
7	WAIT
8	RESET
9	/DSTB
10	WRITE
11	DB7
12	ASTB
13	DB5
14	DB6
15	DB3
16	DB4
17	DB1
18	DB2
19	
20	DB0
21	
22	
23	
24	
25	
26	
27	
28	
29	
30	
31	
32	
33	
34	
35	
36	
37	VDD33
38	
39	GND
40	VU